



WARNING:

CHOKING HAZARD-Small parts.
Not for children under 3 years.

AGES 5+

65268/65266 Asst.

ARMADILLO TANK™

- 1) AUXILIARY REAR-DECK FIGHTING PLATFORM
- 2) REAR ROLL BAR/GRASP RAIL
- 3) PORTABLE GEAR PACK
- 4) WELDED ALUMINUM LAMINATE HULL ARMOR
- 5) ARMORED MAIN BATTLE TURRET
- 6) WEAPONS STORAGE RACK
- 7) OPERATOR COMMAND POST
- 8) 60MM SYNCHRONIZED VARIABLE-RANGE CLUSTER CANNONS
- 9) MAIN GUN CONTROL MECHANISM/HOUSING
- 10) DRIVE-CONTROL ACCESS COVER
- 11) PRIMARY ENGINE RADIATOR
- 12) QUICK-REPAIR HIGH-SPEED TRACK ASSEMBLIES

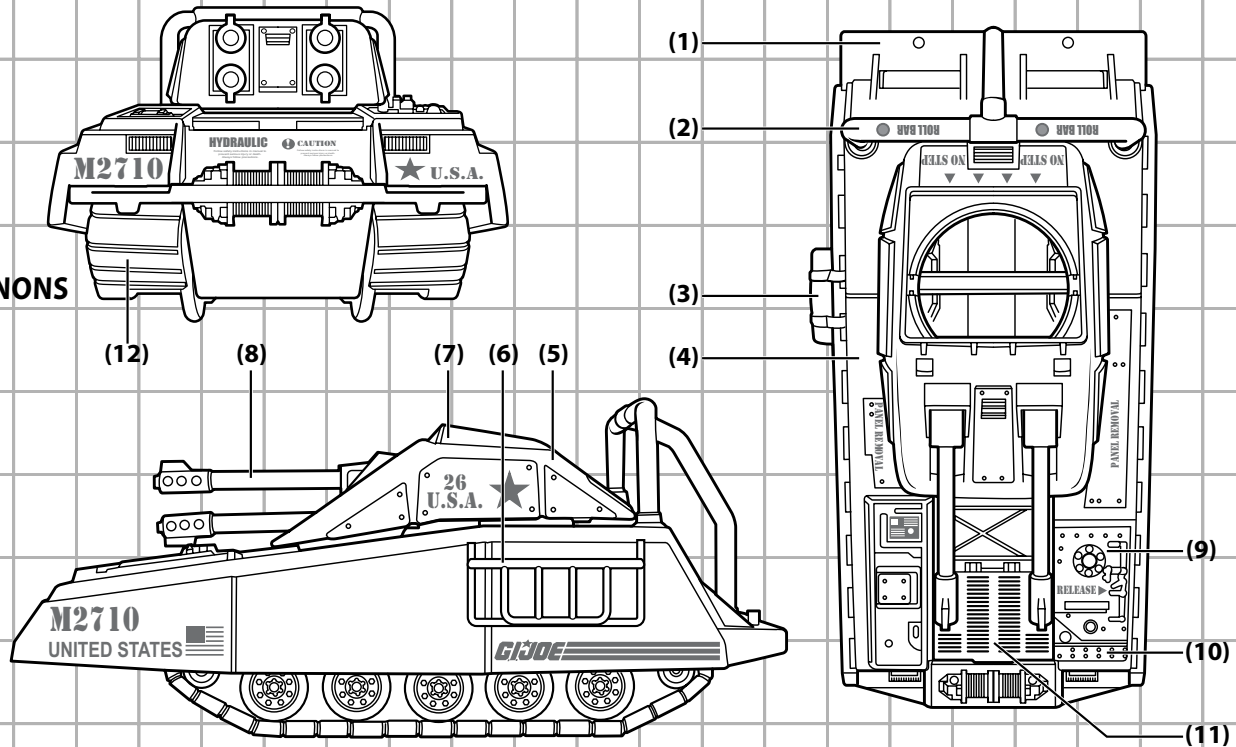

WWW.GIJOE.COM

Peel and apply labels as shown.

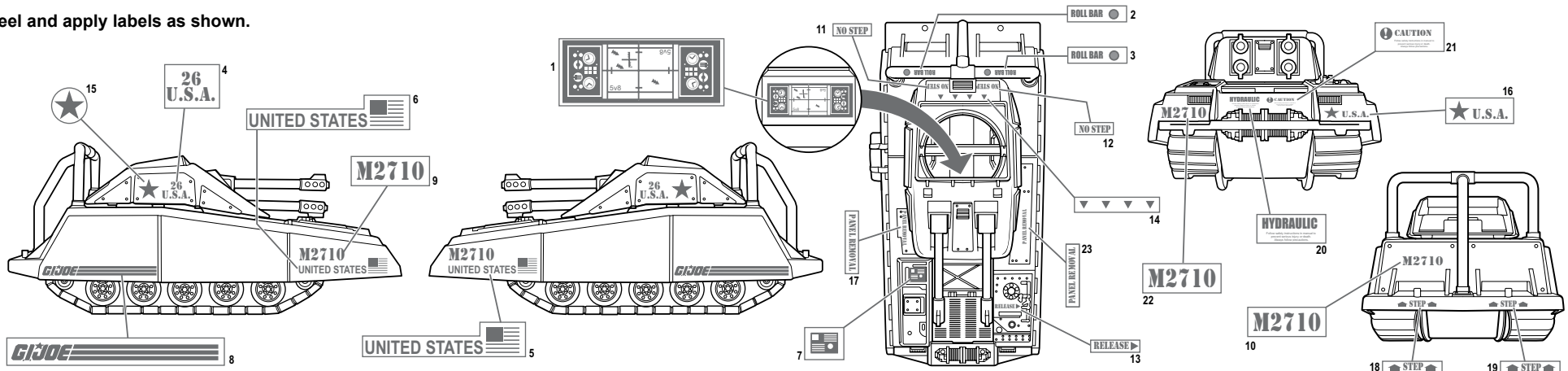



WARNING:

CHOKING HAZARD-Small parts.
Not for children under 3 years.

AGES 5+

65268/65266 Asst.

SERPENTOR'S AIR CHARIOT™

- 1) "COBLAR" FIBER REINFORCED BATTLE SHIELD
- 2) COBRA SHROUD COVERED RADAR UNIT
- 3) VERTICAL PITCH CONTROL/STABILIZERS
- 4) EMP-TWIN TURBOJET ENGINES
- 5) HOVER ENGINE HOUSING INTAKE
- 6) HORIZONTAL GUIDANCE WINGLETS
- 7) AUTO-LOAD 7.62MM "STRIKE" ATTACK GUNS
- 8) COUNTER ROTATING HOVER-PROPS
- 9) POD ROTATION SERVO SYSTEMS
- 10) FINGERTIP ROLLER-TYPE CONTROLS
- 11) BALLISTIC STORAGE COMPARTMENT
- 12) PRESSURIZED MISSILE LAUNCH HOSES
- 13) SECONDARY VERTICAL GUIDANCE STABILIZER

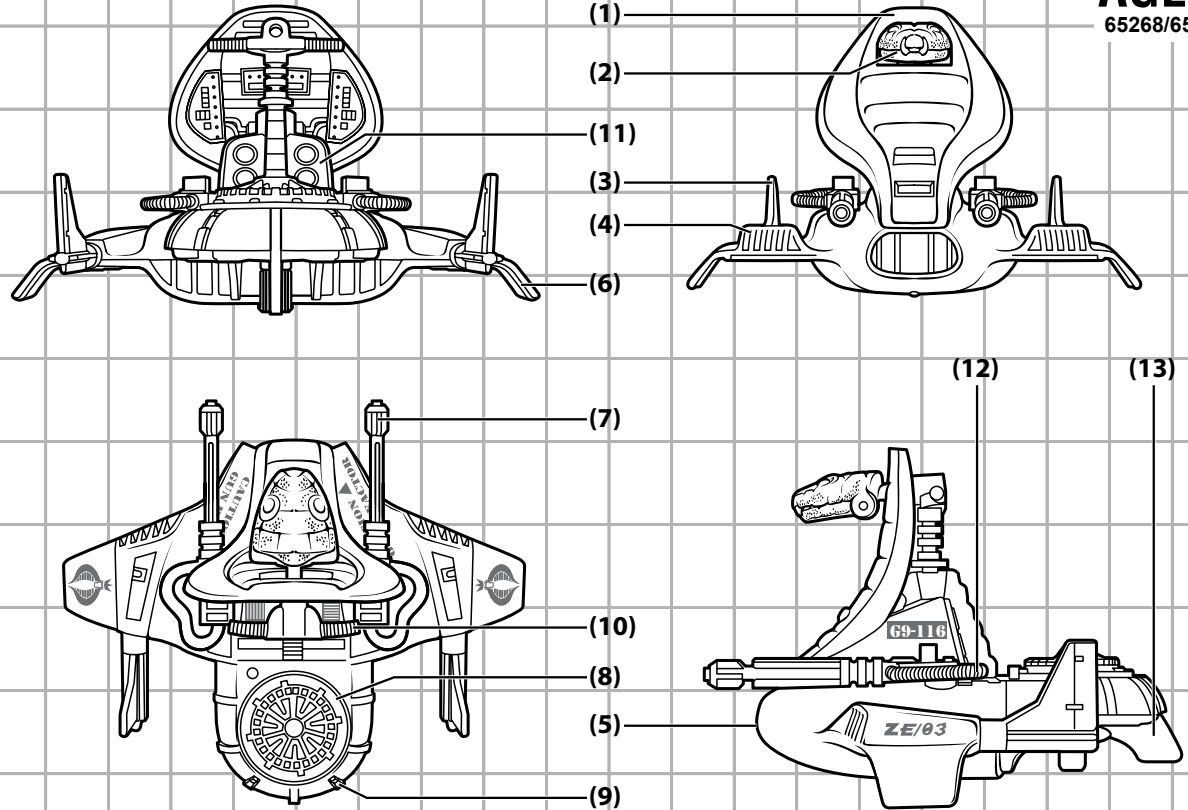

Stand SERPENTOR figure on footpeg with hands on handlebars.

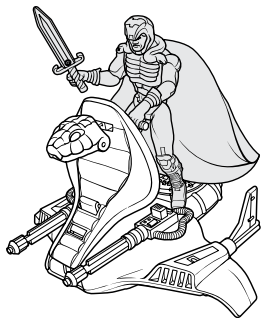

Peel and apply labels as shown.

